

---

**JB 55**

---

**EN OPERATOR'S MANUAL**

**8214-2227-01**

**STIGA®**



## 1 SYMBOLS, SEE FIG. 1

The following symbols can be found on the tiller. Their purpose is to remind you of the care and attention required when using it. If any symbol is missing, damaged or unreadable, it should be immediately replaced with a new one. The symbols mean:

1. Warning! Read the instructions.
2. Warning for rotating blades.
3. Reverse gear.
4. Clutch handle. Handle out, left fig. = disengaged. Handle pressed in, right fig. = engaged.
5. Throttle control, a=fast, b=slow and c=stop.
6. Read the instructions and remove the spark plug lead before doing any work. Wear protective gloves.

## 2 SAFETY INSTRUCTIONS

### 2.1 GENERAL

- Read through this instruction book carefully and make sure you understand the contents before using the tiller.
- The tiller must only be used for gardening purposes.
- Keep children away from the tiller.
- Do not allow children or persons who have not read the instructions to handle the tiller.
- The tiller is manufactured in accordance with current standards, and must not be modified or rebuilt.
- All the symbols on the tiller should be kept intact.
- The user is liable for damages incurred by a third party.



**WARNING for petrol. Petrol is highly inflammable: Petrol must be stored in the requisite containers.**

- Always fill-up outdoors and with the engine switched off.
- Do not smoke when filling-up.
- There must be no naked flames or other sources of heat in the vicinity of the petrol.
- Do not start the engine if petrol has spilled out. Move the machine and allow the petrol to evaporate before starting the machine.
- Screw on the filler cap correctly after filling up.
- Set the throttle control in the "Stop" position, and close the petrol cock when the machine has been stopped.
- Switch off the engine before transporting the machine. Never lift the machine by yourself. The machine is lifted by two persons, one on each side holding the steering and the rotor axle. Wear protective gloves and hold the machine upright when lifting.
- When the machine is loaded on a trailer or tailboard it should be run up on a ramp by using its wheel.

### 2.2 PREPARATIONS

- Before starting work, remove all foreign objects such as stones, glass, cables, metal objects and other loose objects.
- Toys, hoses and other objects can be damaged.
- Check that the tiller is in good condition before using it.
- Check that all nuts and bolts are tightened.

### 2.3 OPERATING

- Always operate the machine at low speed when working on stony ground.
- Do not change the engine's speed setting. The engine must not be overspeeded.
- The work area should be well illuminated during the work.
- The tiller must not be used when other persons, especially children, are in the vicinity.
- The tiller must not be used without the splashguards or protective cover.
- The tiller must not be used if the operator is ill, has taken medicine, or is under the influence of other substances which reduce one's reactions.
- The tiller must not be used on terrain which slopes more than 20°.
- The user is responsible to ensure that all risks in the terrain are taken into consideration, and that procedures are taken to prevent accidents. This particularly applies to sloping, slippery or loose terrain.
- Start the engine carefully, according to the instructions in this manual. No parts of the body must come in contact with the rotors.
- The engine must never be started in an enclosed area.
- The carbon monoxide in the engine's exhaust fumes is poisonous and can cause death.
- Wear tightly fitting clothes and heavy-duty shoes which completely cover the feet.
- The tank should only be half full when operating on slopes. Petrol can leak out.
- The engine must be stopped in the following circumstances:
  - When the machine is left unattended
  - Before the machine is filled up with petrol
- Always make sure you have a good footing, especially on slopes.
- Check that no one is in front of you or beside you when starting the blades. Keep a steady grip on the steering. The machine will lift when the rotors are started. Use extra caution when backing.

- Always keep at a safe distance to the rotors when working.
- Holding the steering correctly ensures a safe distance.
- No person must come closer than 20 m to the machine when working on slopes. The user must hold the steering firmly with both hands all the time.
- Working on stony or hard ground demands extra attention from the operator. The machine becomes more unstable.
- Never touch the engine when operating the machine, or just afterwards. Risk for burn injuries.

#### 2.4 AFTER OPERATING

- Allow the engine to cool before putting the machine in a storeroom. Fire risk!
- Remove dirt and foreign material before putting the machine in a storeroom. The area round the petrol tank and muffler must be kept clean from leaves, oil, petrol or other foreign materials. Fire risk!
- If the petrol tank is to be emptied, do this outdoors and when the engine is cold. Fire risk!
- The machine should be stored in a dry place. The machine must not be stored with fuel in the tank in rooms where there are naked flames, sparks or other strong sources of heat.

#### 2.5 MAINTENANCE

- Carry out maintenance regularly. All nuts and bolts should always be tight.
- Only use genuine spare parts which are in good condition. Spare parts must not be repaired. They must be replaced if they are defective. Poor quality spare parts can lead to personal injury. If the muffler is damaged it must be replaced.
- The engine must be stopped and the spark plug lead disconnected in the following circumstances:

When adjusting the rotors.

When the machine is to be cleaned or repaired. When checking after a collision with a solid hard object. Carry out the necessary repairs before continuing to work.

If the machine begins to vibrate abnormally. Carry out the necessary repairs before continuing to work.

- Wear protective gloves when working with the rotors.

### 3 DELIVERY

The tiller is delivered in a box with the steering and side plates dismantled. All the wires are fitted and adjusted.



**WARNING! There is no oil in the engine on delivery.**

### 4 DESCRIPTION, SEE FIG. 2

The tiller is driven by a four-stroke engine and consists of the following parts:

1. Clutch control, activation of the blades
2. Gear control, forward/reverse
3. Steering adjuster
4. Air filter
5. Manual start
6. Splashguard
7. Tail brake
8. Data plate
9. Side roller
10. Throttle control
11. Fuel tank
12. Oil filler
13. Oil plug
14. Support wheel
15. Rotors, 4, the outer rotors can be removed. The working width then becomes 340 mm
16. Cover
17. Cover for muffler
18. Exhaust
19. Handle

The data plate (8) contains the following information. See fig. 3.

- A Nominal power
- B Weight in kg
- C Serial number
- D Year of manufacture
- E Type F Manufacturer
- G CE-mark
- H Max. engine speed

### 5 ASSEMBLY

#### 5.1 STEERING, SEE FIG. 4

Fit the steering (1) according to the figure with the bolt (2), washer (3), nut (4), bolt (5), washer (6) and nut (7). Choose a suitable hole for the bolt (5) for comfortable adjustment of the steering (1).

#### 5.2 SPLASHGUARD, SEE FIG. 2

Fit the splashguards (6) on both sides with the enclosed nuts and bolts.

### 5.3 SUPPORT WHEEL, SEE FIG. 5

Fit the support wheel according to the figure. Do not tighten the nut (5) too hard. It will not be possible to fold the wheel arm up.

### 5.4 FILLING THE OIL, SEE FIG. 2

Remove the plug (12) and fill up with 0.7 L of oil, SAE 10W40. Screw the plug back on.

### 5.5 ROTORS AND SIDE ROLLERS, SEE FIG. 6

The first rotor (1) is pushed on the axle shaft (2) and locked with the cotter (3). After which the second rotor (4) is inserted in the first and locked with the cotter (3). Max. 3 rotors can be fitted in this way on each side. Finally, fit the side rollers in the same way.

**WARNING! Check that the cotters are locked,**

i.e. that the springs are locked round the shaft.

---

## 6 OPERATING

---

See also section 2.3.



**WARNING! Check the engine's oil level. See section 8.4.**

### 6.1 FILLING THE FUEL, SEE FIG. 7

See the safety instructions in section 2.1. Fill up with 2.8 L of unleaded petrol, and screw on the filler cap.

**NOTE!** Remember that standard unleaded petrol is perishable. Do not buy more petrol than what can be consumed in 30 days. Environmentally adapted petrol (acrylic petrol) can be used to advantage. This petrol is more environmentally-friendly.

### 6.2 START

See the safety instructions in section 2.3. A cold engine is started as follows:

1. Open the petrol cock. See fig. 8.
2. Set the choke lever in the choke position. See fig. 11b.
3. Set the throttle control to idle. See fig. 10.
4. Pull the starter handle, first gently until the pawls grip, and then with a strong tug until the engine starts. See (5) in fig 2.  
**NOTE!** Do not let go of the cord when the engine has started, but follow it back slowly with your hand!
5. Set the throttle control in mid position.
6. Set the choke in position "Run". See fig 9. A warm engine is started in the same way as above, but without steps 2 and 6.

### 6.3 FORWARD OPERATION, SEE FIG. 2.

Forward gear is selected when the left handle, the gear control (2), is not pushed in. The tiller starts forward when the clutch handle (1) is pulled in. Go forwards as follows:

1. Set the throttle control (10) in the required position.
2. Pull in the clutch handle (1). The tiller stops moving forward when the clutch handle (1) is released.

### 6.4 BACKWARD OPERATION, SEE FIG. 2

 **WARNING! The gear control (2) must only be pulled in when the clutch handle (1) is not pulled in.**

Go backwards as follows:

1. Set the throttle control (10) in the required position.
2. Pull in the gear control (2).
3. Pull in the clutch handle (1). The tiller stops moving backwards when both handles are released.

### 6.5 STOPPING, SEE FIG. 11

Stop the tiller as follows: 1 Set the throttle control in stop position. See fig. 11a 2 Set the choke lever in choke position. See fig. 11b. 3 Close the petrol cock. See fig. 11c.

### 6.6 OPERATING TIPS

The rotors drive the machine forward. The speed of the rotors is regulated with the throttle control.



**WARNING! Keep hands and feet away from the rotors.**

Adjust the number of rotors on each side to the required working width. See section 5.5.

When the machine is braked with the help of the tail brake, the rotors dig down into the earth. The working depth depends upon how much the tail brake is forced down into the ground while working. The correct working depth determines how easily the work is done. The optimal working depth varies with the ground conditions. Try it and see.

Never use the machine in wet soil. Lumps form, which are then difficult to crush. Hard and dry soil necessitates making a second run, at right angles to the first.



**WARNING! Never overload a new machine. Run the machine carefully the first 5 hours.**

---

## 7 STORAGE

---

The tiller should be stored in a dry place.

See also section

2.4.

After the petrol has been drained off, start the engine and allow it to run until all the remaining petrol is used up.

## 8 MAINTENANCE



**WARNING! Repairs must be carried out by the dealer. Otherwise the warranty is not valid.**



**WARNING! The spark plug lead should be disconnected before carrying out repairs or maintenance.**

### 8.1 PERIODIC MAINTENANCE

#### 8.1.1 Before using the machine

- Check the oil level in the engine. Top up if necessary.
- Check that there is no oil leakage.
- Check that all the bolts are tightened.

#### 8.1.2 After using the machine

- Clean the tiller.
- Check that there is no oil leakage.

#### 8.1.3 Every 20 working hours

- Check, and clean or replace the air filter.
- Check that all nuts and bolts are tightened.

#### 8.1.3 Change the oil in the engine every year.

### 8.2 TO DRAIN OFF THE PETROL

see section 2.4.

### 8.3 AIR FILTER, SEE FIG. 12

Clean/change the air filter regularly. Unscrew the screw (A) to remove the air filter.



**WARNING! Never use inflammable liquids when cleaning.**

Clean the air filter by brushing it clean with a soft brush.

### 8.4 CHANGING/CHECKING THE OIL, SEE FIG. 2

The engine oil should be changed every year. Change the oil as follows:

1. Run the engine warm. **WARNING!** The engine oil is hot. Risk for burn injuries.
2. Tilt the machine forward and remove the plug (13).  
Drain off the oil into a suitable container. Fit the plug when the oil is drained off.
3. Put the machine horizontal.
4. Remove the plug (12) and fill up with 0.7 L of oil, SAE 10W40. Screw the plug back on.
5. The oil level should be level with the bottom edge of the hole for the plug (12) when the machine is horizontal.

### 8.5 CLEANING

See section 2.4. First brush off all the loose dirt. Then wipe the tiller with a damp cloth. The frame can be flushed clean with water.

### 8.6 REPLACEMENT OF DRIVE BELT, SEE FIG 13

1. Remove the cover (16) in fig. 2.
2. Lift the tensioning pulley (2) and work off the belt.
3. Work off the belt from the two pulleys. The clamp (A) over the small pulley should not be removed.
4. Fit the new belt in the reverse order.
5. Adjust the clutch wire. See below.
6. Fit the cover.

### 8.7 ADJUSTING THE CLUTCH WIRE

1. Remove the cover (16) in fig. 2.
2. Adjust the clutch wire with the tensioning sleeve (A) in fig. 14.
3. The clutch wire is correctly adjusted when the spring (B) in fig. 15 extends approx. 1 cm when the handle is pressed in.
4. Lock the tensioning sleeve and fit the cover after adjusting.

### 8.8 ADJUSTING THE GEAR WIRE

1. Adjust the gear wire with the tensioning sleeve (C) in fig. 16.
2. The gear wire is correctly adjusted when the play in the end of the handle is approx. 5 mm. See fig. 17.

**NOTE!** Do not tighten the gear wire too hard. This can reduce its lifetime.

3. Lock the tensioning sleeve after adjusting.

### 8.9 TROUBLE SHOOTING

#### 8.9.1 Fault: Difficult to start.

Reason: The fuel is too old.

Procedure: Drain the tank and fill up with new petrol.

Reason: Fault on spark plug.

Procedure: Replace spark plug.

#### 8.9.2 Fault: The engine does not run smoothly.

Reason: Dirt in the fuel.

Procedure: Clean the petrol tank and carburettor.

Reason: Fault on spark plug.

Procedure: Replace spark plug.

#### 8.9.3 Fault: The engine has no power, will not run at full throttle.

Reason: Blocked air filter.

Procedure: Clean or replace air filter.

8.9.4 Fault: Slips when moving forward.

Reason: The belt is too slack.

Procedure: Adjust the belt.

8.9.5 Fault: Slips when moving backward.

Reason: The gear control is incorrectly adjusted.

Procedure: Adjust the gear control.

8.9.6 Fault: Stops under operation.

Reason: Run out of fuel.

Procedure: Fill up with petrol.

---

## 9 TECHNICAL DATA

---

Weight:	46 kg
Type of engine:	4-stroke, Briggs & Stratton
Spark plug:	Champion QC12YC or the equivalent.
Power:	4 kW (5.5 hp)
Engine speed:	3400 rpm
Sound pressure level:	77 dB(A)
Vibration level:	2.9 m/s <sup>2</sup>
Transmission:	Belt gear with gearbox
Fuel tank, capacity:	2.8 litres
Fuel:	95 octane, unleaded petrol
Steering handles:	Vertically adjustable.
Blade diameter:	320 mm
Working width:	590 mm (840 mm with 6 rotors and 340 mm with 2 rotors)
Rotation of blades forward:	135 rpm
Rotation of blades backward:	58 rpm

---

## 10 CE CERTIFICATE

---

Ets PUBERT SA Z.I. de Pierre-Brune, 85110 CHANTONNAY, France warrants that tiller JB 55 complies with the essential health and safety requirements in the directives 89/392 CEE and 98/37/CE. To guarantee correct application of the safety and health requirements stipulated in the EEC Directive, the following standards and/or technical specifications have been consulted: EN 292-1, EN 292-2, EN 25349 (1993) and NFU 02-025.

Chantonnay 01 01 99

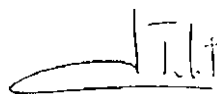

M. Jean-Pierre PUBERT  
Chairman and CEO

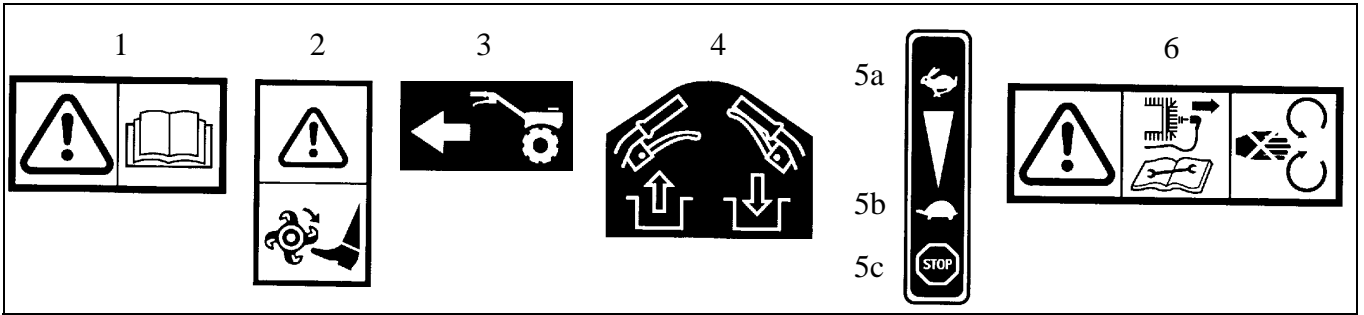

Fig. 1

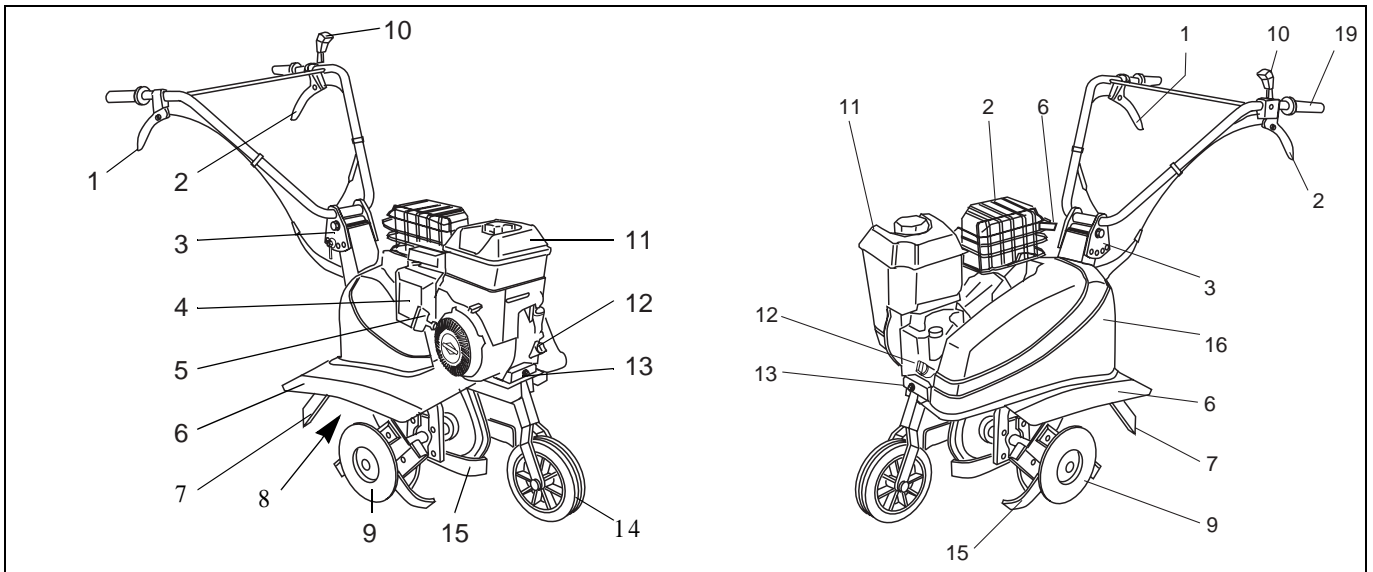

Fig. 2

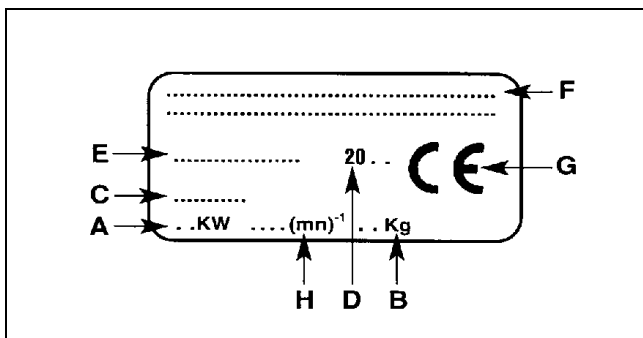

Fig. 3.

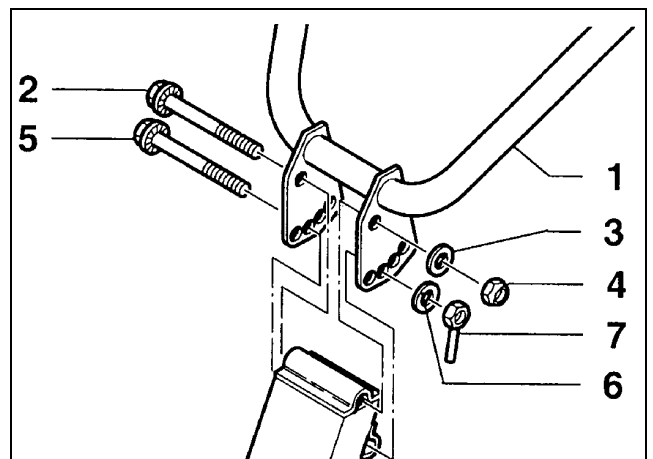

Fig. 4.



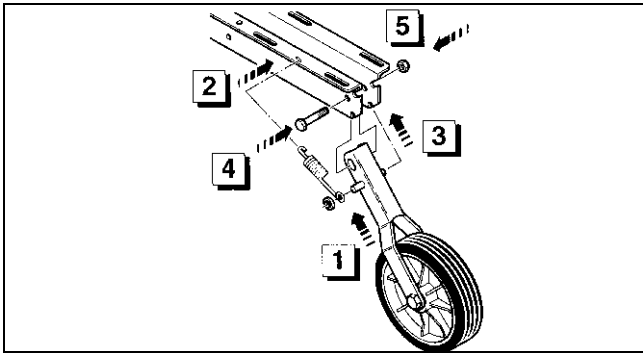

Fig. 5.

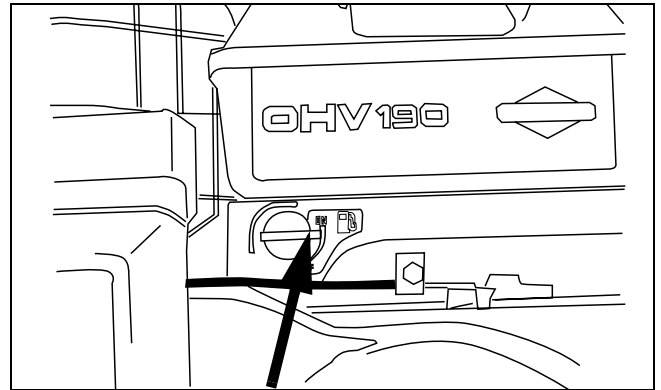

Fig. 8.

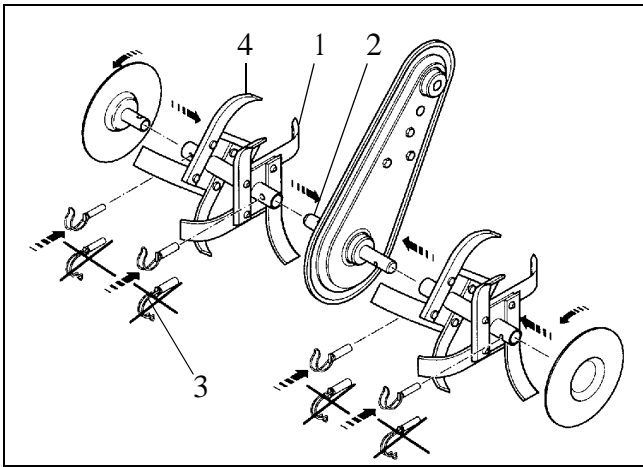

Fig. 6.

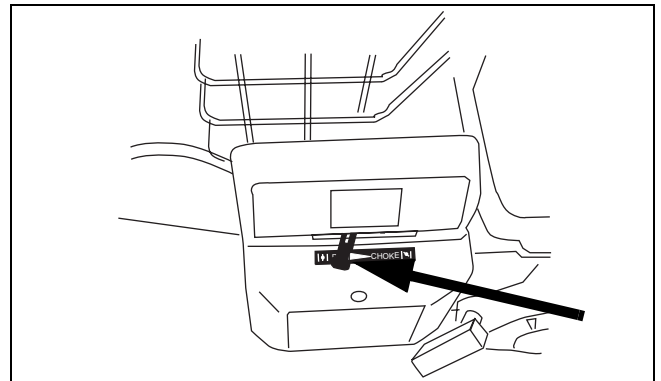

Fig. 9.



Fig. 7.

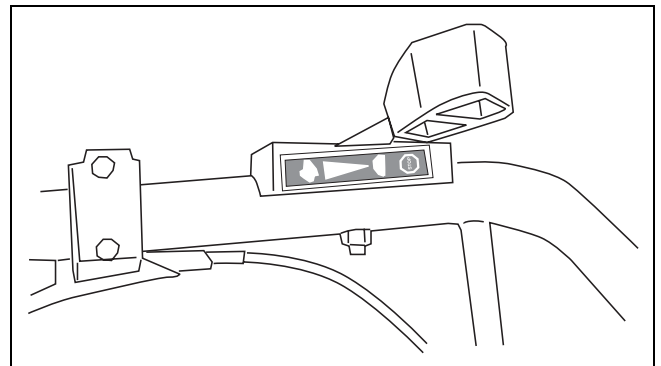

Fig. 10.

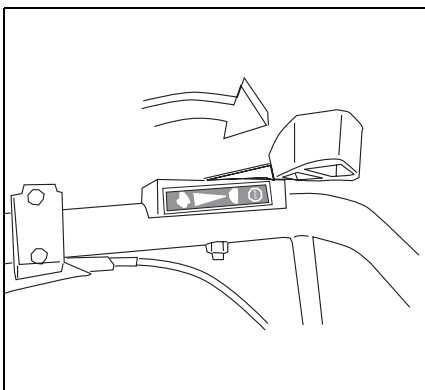

Fig. 11a.

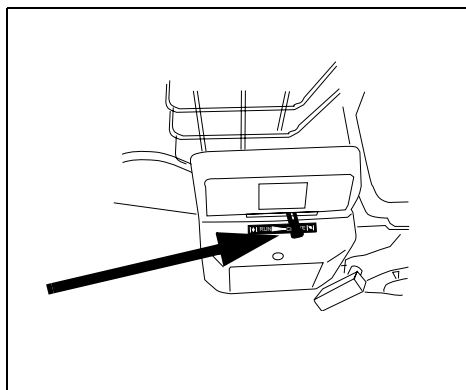

Fig. 11b.

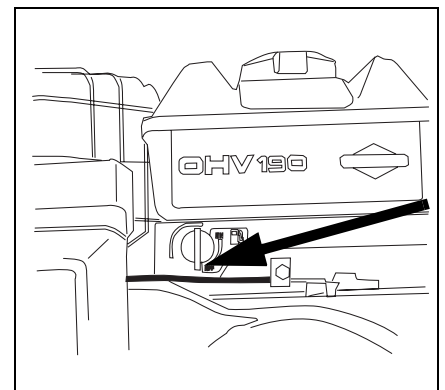

Fig. 11c.

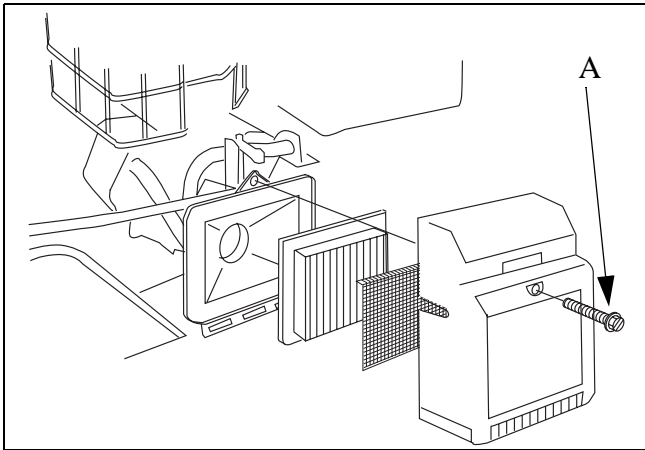

Fig. 12.

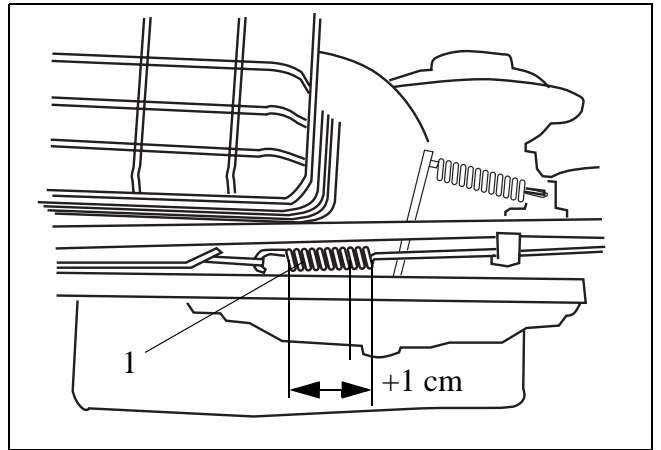

Fig. 15.

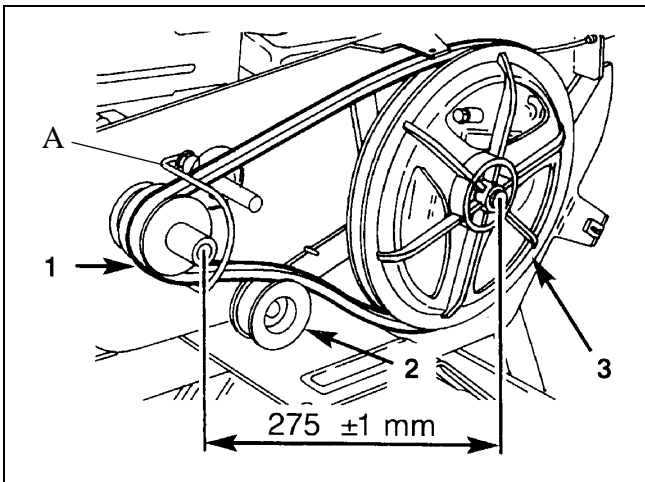

Fig. 13.

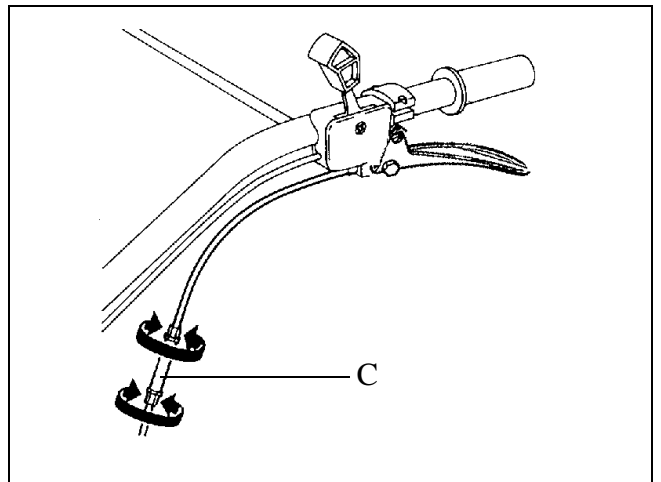

Fig. 16.

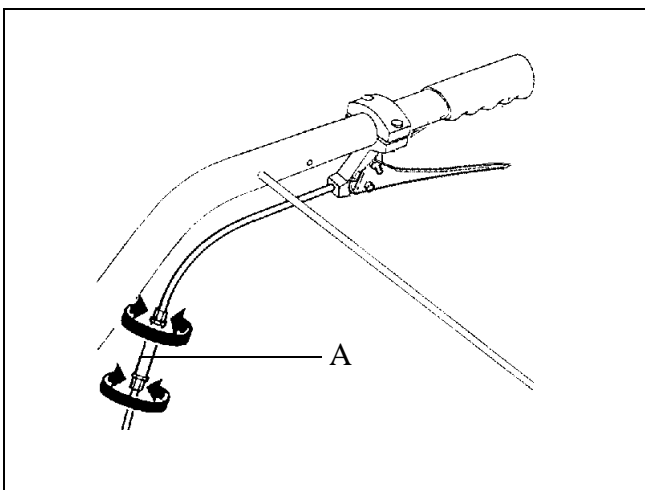

Fig. 14.

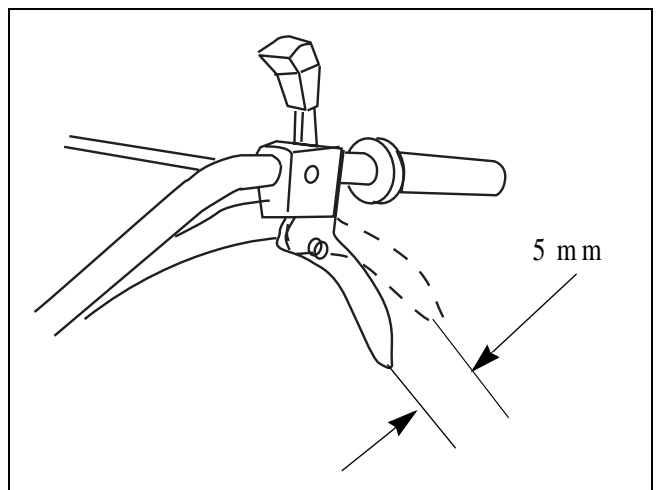

Fig. 17.

**STIGA®**